

FPP33WC100AAU5D0N

## FIXED CASTOR Ø 100 MM SERIES AAU5 DOUBLE BALL BEARING

### WHEEL

wheel diameter in mm	100
wheel width in mm	40
hub width in mm	50
screw size	M8
tread	polyurethane 92° shore A brown
wheel center	aluminium
bearing	double ball bearing
threadguard	without separate threadguard
temperature range	-20°C to +60°C



### HOUSING

material thickness fitting in mm	3.00
material thickness fork in mm	3.00
fitting	plate
mounting dimension in mm	80 / 77 x 60
offset dimension in mm	0
total height in mm	128
swivel radius in mm	0
dyn. load capacity in kg	250
test norm	DIN EN 12532

**CASCOO Europe GmbH**

Lütke Haar 15 • 59602 Rüthen • Germany  
+49 2952 - 970629-0  
info@cascoo.eu • www.cascoo.eu

FPP33WC100AAU5D0N

# FIXED CASTOR Ø 100 MM SERIES AAU5 DOUBLE BALL BEARING

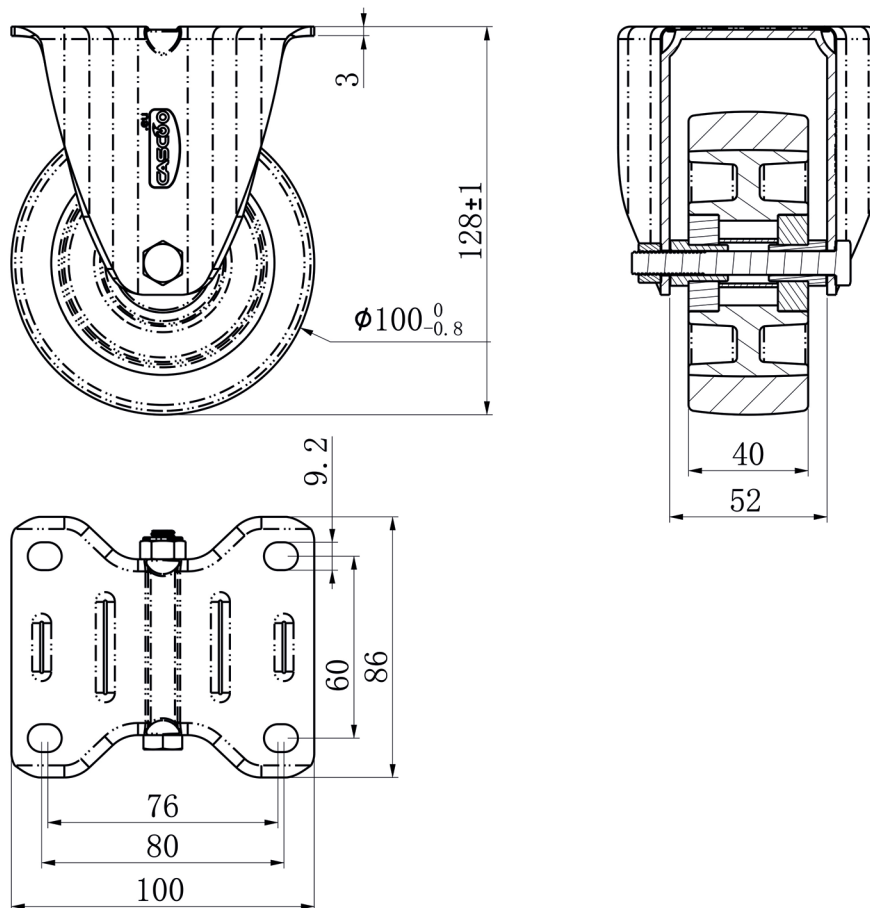

**CASCOO Europe GmbH**

Lütke Haar 15 • 59602 Rüthen • Germany  
+49 2952 - 970629-0  
info@cascoo.eu • www.cascoo.eu